

μGrind booster HPS 20 / HPS 20 L

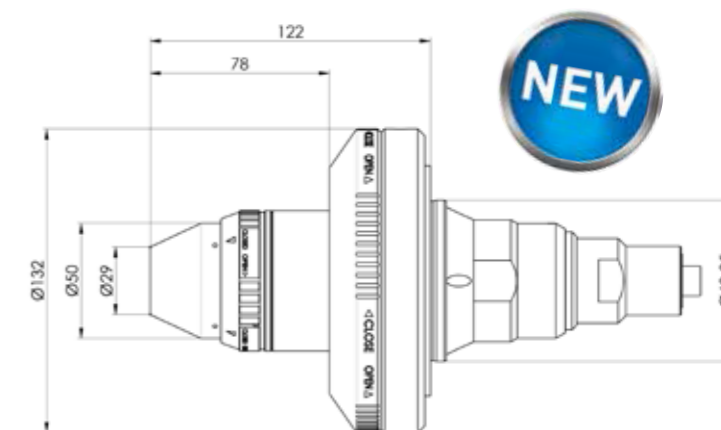

μGrind booster HPS 20 / HPS 20 L

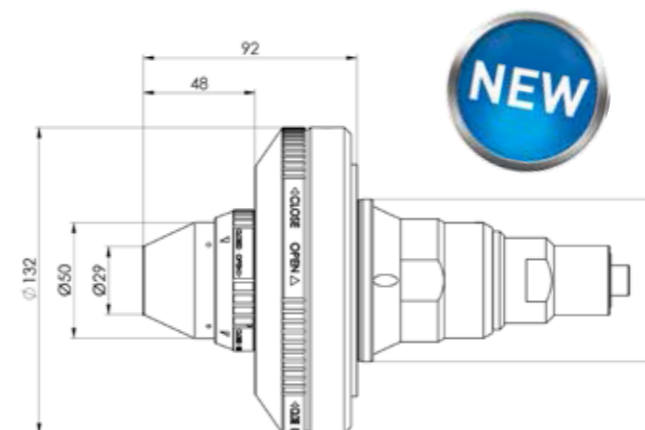

Delivery includes:

Case, actuating pushrod, adjustment hammer, wrench, USB flash drive with instructions

Item No.	Name	D	L
400001000	μGrind booster HPS 20	69,95	92
400001001	μGrind booster HPS 20 L	69,95	122

Available for following machine(s):



- Helitronic Vision
- Helitronic Power
- Helitronic Mini Power
- Helitronic Essential
- Measuring machines: Helicheck



HPS collets see on the following pages.

Item No.	Name
350270002	Alignment set HPS (excl. dial gauges) Incl. HPS collets ø8 and ø10, test pin ø8 and ø10 dial gauges available separately
350270003	Dial gauges (2 pcs.)



Item No.	Name
350290001	Adapter flange ANCA with actuating pushrod



- Available for following machine(s):
ANCA MX 5, ANCA MX 7

HPS collets for μ Grind booster HPS 20 // HPS 20 L and xGrind



Accessories flat collets:

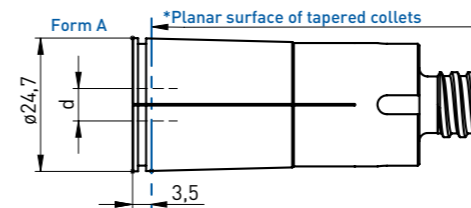

Item No.	Name - ϕ d	Form
350260003	HPS collet 20 - ϕ 3 mm	A
350260004	HPS collet 20 - ϕ 4 mm	A
350260005	HPS collet 20 - ϕ 5 mm	A
350260006	HPS collet 20 - ϕ 6 mm	A
350260007	HPS collet 20 - ϕ 7 mm	A
350260008	HPS collet 20 - ϕ 8 mm	A
350260009	HPS collet 20 - ϕ 9 mm	A
350260010	HPS collet 20 - ϕ 10 mm	A
350260011	HPS collet 20 - ϕ 11 mm	A
350260012	HPS collet 20 - ϕ 12 mm	A
350260013	HPS collet 20 - ϕ 13 mm	A
350260014	HPS collet 20 - ϕ 14 mm	A
350260015	HPS collet 20 - ϕ 15 mm	A
350260016	HPS collet 20 - ϕ 16 mm	A
350260017	HPS collet 20 - ϕ 17 mm	A
350260018	HPS collet 20 - ϕ 18 mm	A
350260019	HPS collet 20 - ϕ 19 mm	A
350260020	HPS collet 20 - ϕ 20 mm	A
350260201	HPS collet 20 - ϕ 1/8"	A
350260202	HPS collet 20 - ϕ 3/16"	A
350260203	HPS collet 20 - ϕ 1/4"	A
350260204	HPS collet 20 - ϕ 5/16"	A
350260205	HPS collet 20 - ϕ 3/8"	A
350260206	HPS collet 20 - ϕ 7/16"	A
350260207	HPS collet 20 - ϕ 1/2"	A
350260208	HPS collet 20 - ϕ 9/16"	A
350260209	HPS collet 20 - ϕ 5/8"	A
350260210	HPS collet 20 - ϕ 11/16"	A
350260211	HPS collet 20 - ϕ 3/4"	A

Accessories tapered collets:

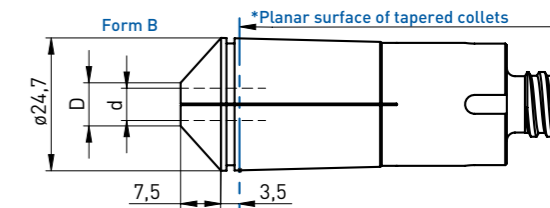

Item No.	Name - ϕ d	Form
350260130	HPS collet 20K - ϕ 2,35 mm	B
350260103	HPS collet 20K - ϕ 3 mm	B
350260104	HPS collet 20K - ϕ 4 mm	B
350260105	HPS collet 20K - ϕ 5 mm	B
350260106	HPS collet 20K - ϕ 6 mm	B
350260301	HPS collet 20K - ϕ 1/8"	B
350260302	HPS collet 20K - ϕ 3/16"	B
350260303	HPS collet 20K - ϕ 1/4"	B

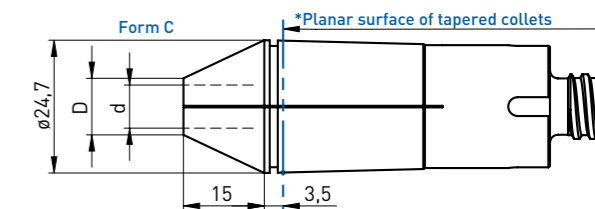

Item No.	Name - ϕ d	Form
350260107	HPS collet 20K - ϕ 7 mm	C
350260108	HPS collet 20K - ϕ 8 mm	C
350260109	HPS collet 20K - ϕ 9 mm	C
350260110	HPS collet 20K - ϕ 10 mm	C
350260111	HPS collet 20K - ϕ 11 mm	C
350260112	HPS collet 20K - ϕ 12 mm	C
350260304	HPS collet 20K - ϕ 5/16"	C
350260305	HPS collet 20K - ϕ 3/8"	C
350260306	HPS collet 20K - ϕ 7/16"	C
350260307	HPS collet 20K - ϕ 1/2"	C

TIP Minimum clamping depth of 2,5 x ϕ from *clamping chuck's plane surface.